

# Empirical Role of Islamic Cooperatives in Financing Micro and Small Scale Entrepreneurs in Indonesia: Case Study of KOSPIN Jasa Syariah Pekalongan

Irfan Syauqi Beik<sup>1</sup>  
Indah Purnamasari<sup>2</sup>

*One of the major problems faced by micro and small scale entrepreneurs (MSE) is lack of financial access. The presence of Islamic microfinancing institution (IMI) is extremely important. IMI offers simpler administrative and requirement procedures as compared to the commercial banks. One of the IMIs that exist in Indonesia is Islamic cooperatives. This paper attempts to observe empirical role of Islamic cooperatives in the country by taking a case study of Kospin Jasa Syariah in Pekalongan city, Central Java. It is the biggest Islamic cooperative based on the assessment of Ministry of Cooperatives and Small and Medium Scale Enterprises. The study aims at analyzing effectiveness level of financing given to the MSI and factors affecting the financing amount taken by these MSE. A survey on 100 micro and small scale entrepreneurs was conducted on February, 2011. Likert scale and path analysis were employed as analytical tools. The study found that financing procedures and financing impact on the entrepreneurs were effective. Administrative cost and education level are also found to be the most significant factors affecting financing amount proposed by the MSE. On the other hand, the study concluded that business income, profit earned and household consumption, had significant impact on post-financing income level of the MSE. In general, Kospin Jasa Syariah was empirically proven to be able to increase income level of the MSE.*

**Keywords:** Islamic cooperatives, Islamic financing, path analysis

## I. INTRODUCTION

The role of micro, small and medium scale enterprises (MSME) in Indonesia's economy is undeniably important. This can be observed from economic contribution of MSME towards Indonesia's GDP and absorption of labor force. As has been depicted in the Table 1 below, the number of MSME operating in the country reaches 52.76 million units in the year 2009, or equals 99.99 percent of total business unit. They are able to contribute 56.53 percent to the total GDP, although their export is less than one-fifth of the total non oil and gas export (Central Board of Statistic, 2010).

In terms of labor force, majority of them are working in MSME. MSME can absorb 96.2 million workers, which equals 97.30 percent of the total national work force. These facts indicate that the presence of MSME is highly influential in the country's economic development.

---

<sup>1</sup> Head of Islamic Economics Program, Department of Economics, Executive Secretary, Centre for Islamic Business and Economic Studies Bogor Agricultural University, Indonesia, Email: qibeiktop@yahoo.com

<sup>2</sup> Researcher, Centre for Islamic Business and Economic Studies, Bogor Agricultural University, Indonesia, Email: queenpink.black@gmail.com

Table 1: Key Indicators of MSME and Large Scale Enterprises in Indonesia

No	Indicators	2008		2009	
		Total	Share (%)	Total	Share (%)
1	<b>Business Unit:</b>	51,414,262 unit	100.00	52,769,280 unit	100.00
	Micro Scale Enterprises	50,847,771 unit	98.90	52,176,795 unit	98.88
	Small Scale Enterprises	532,124 unit	1.02	546,675 unit	1.04
	Medium Scale Enterprises	39,717 unit	0.08	41,133 unit	0.08
	Total MSME	51,409,612 unit	99.99	52,764,603 unit	99.99
	Large Scale Enterprises	4,650 unit	0.01	4,677 unit	0.01
2	<b>Labor Force (persons):</b>	96,780,483	100.00	98,886,003	100.00
	Micro Scale Enterprises	87,810,366	90.73	90,012,694	91.03
	Small Scale Enterprises	3,519,843	3.64	3,521,073	3.56
	Medium Scale Enterprises	2,694,069	2.78	2,667,565	2.71
	Total MSME	92,024,278	97.15	96,211,322	97.30
	Large Scale Enterprises	2,756,205	2.85	2,674,671	2.70
3	<b>Gross Domestic Product based on current price</b>				
	<b>(in billion Rupiah):</b>	4,693,809.0	100.00	5,294,860.9	100.00
	Micro Scale Enterprises	1,510,055.8	32.17	1,751,644.6	33.08
	Small Scale Enterprises	472,830.3	10.07	528,244.2	9.98
	Medium Scale Enterprises	630,339.9	13.43	713,262.9	13.47
	Total MSME	2,613,226.1	55.67	2,993,151.7	56.53
Large Scale Enterprises	2,080,582.9	44.33	2,301,709.2	43.47	
4	<b>Non Oil and Gas Export (in billion Rupiah)</b>	983,540.4	100.00	953,089.9	100.00
	Micro Scale Enterprises	16,464.8	1.67	14,375.3	1.51
	Small Scale Enterprises	40,062.5	4.07	36,839.7	3.87
	Medium Scale Enterprises	121,481.0	12.35	111,089.6	11.65
	Total MSME	178,008.3	18.10	162,254.5	17.02
	Large Scale Enterprises	805,532.1	81.90	790,835.3	82.98

Source: Central Board of Statistic (2010)

By definition, according to Law No. 20/2008, micro enterprises or business in Indonesia is defined as productive business owned by individual or *recht person* (legal entity) whose assets are less than Rp 50 million (USD 5,813.95)<sup>3</sup> and whose annual turnover are not exceeding Rp 300 million (USD 34,883.70). As for small scale business, the total assets are in between Rp 50 million and Rp 500 million (USD 5,813.95 – USD 58,139.5), while the annual business turnover are in between Rp 300 million and Rp 2.50 billion (USD 34,883.70 – USD 290,697.67).

One major problem faced by most of the micro and small scale business (MSE) is their limited access to financial resources. Bankability is the specter which haunts MSE and keeps them away from banking industry. Hence, providing inclusive financial access is the best option to improve and enlarge their business capacity. The presence of Islamic microfinancing institutions (IMI), such as Islamic cooperatives, Islamic rural banks, and *Baytul Maal wat Tamwil* (BMT) in Indonesia, has supported development of MSE

<sup>3</sup> USD 1 equals Rp 8,600. Hence, Rp 50 million will be equal to USD 5,813.95.

significantly. These institutions are expected to play more significant role in stimulating real sector growth by reducing the gap between MSE and financial resources.

Looking at actual condition of the economy, it seems that the role of Islamic microfinancing institution (IMI) tends to increase from time to time. Islamic cooperative is one of the types of IMIs which consistently grow up rapidly for the last two decades. Its emergence was in line with growing public awareness to find alternative to contemporary financial institution. In addition to shariah compliance aspect, Islamic cooperative offers simpler and easier financing requirements as compared to commercial banks. This is the strength of Islamic cooperative, which favors micro and small scale enterprises (MSE).

This paper tries to focus on the empirical role played by Islamic cooperative in financing micro and small scale enterprises (MSE). In this regard, *Koperasi Simpan Pinjam (KOSPIN) Jasa Syariah* is taken as case study. Initially, Kospin Jasa Syariah was set up on August 17, 2004 in Pekalongan city<sup>4</sup> as an Islamic business unit of the conventional Kospin. However, growth of this Kospin Jasa Syariah was so fast, making it as a prominent Islamic cooperative institution in the country. This growth can be observed in terms of asset, which witnesses a substantial improvement in Kospin's asset within four years. In the year 2005, total asset of Kospin Jasa Syariah reached Rp 12.76 billion (USD 1.48 million), while in the year 2009, this asset has increased to Rp 66.05 billion (Kospin Financial Report, 2010).

In terms of savings, the number of deposited fund has increased from Rp 7.22 billion (USD 840,000) in 2005 to Rp 58.67 billion (USD 6.82 million) in 2009. Similarly, the amount of financing given by Kospin Jasa Syariah during the same period has also gone up from Rp 11.50 billion (USD 1.34 million) to Rp 59.69 billion (USD 6.94 million). This remarkable rise within short period of time indicates that Kospin Jasa Syariah was able to demonstrate good performance.

Despite good performance, Kospin Jasa Syariah must continuously enhance its internal management in order to meet global economic challenges, which may affect institutional sustainability. Managerial effectiveness and efficiency are the key factors influencing competitiveness level of the organization. Hence, evaluation on the cooperative performance, which may also affect its profitability, should be periodically conducted.

This study attempts to analyze effectiveness level of financing, which is observed from financing performance comprising financing procedure and impact. It also tries to analyze factors affecting financing demand made by MSE and financing impact on income and profitability of MSE that become members of Kospin Jasa Syariah.

This paper comprises five sections including introduction as the first one. Characteristics and unique feature of Islamic cooperatives as well as other relevant literature are elaborated in the section two. Section three discusses methodology used in this study, followed by analysis on research findings in the section four. Last section concludes the paper.

---

<sup>4</sup> Pekalongan city is located in the province of Central Java. As of current condition, Kospin has opened branches in some other provinces in Indonesia.

## II. LITERATURE REVIEW

Islamic cooperative is basically conversion of conventional cooperative through an approach that is in line with shariah. Conceptually, establishment of Islamic cooperative is using the concept of *shirkah mufawadoh* in which all parties involved contributes fund in the same portion as well as equally participate in managing the organization. In the practice of cooperatives, no one is allowed to inject bigger amount of fund and receive bigger portion of profit as compared to the others (Kospin Jasa Syariah, 2009).

Basic principle of cooperative is on strong cooperation among members. Monopolistic practices will not take place since profit and loss are shared among the members. Members' annual meeting is the highest *shuratic* forum in which all strategic decisions are made. Each member has equal vote and opportunity to express idea and opinion. According to Buchori (2009), there are five major characteristics of Islamic cooperative.

Firstly, acknowledging member's ownership right on business capital. Secondly, riba-based transactions are not allowed in any circumstances. Thirdly, institution of ZISWAF (zakat, infak, sadaqah and waqf) is functioning well. Fourthly, admitting profit-oriented motive as long as shariah principles are strictly followed. Fifthly, acknowledging freedom of business and economic endeavors. Sixthly, acknowledging common rights.

When Islamic cooperative is compared with its conventional counterpart, there exist at least five main differences (Hidayat, 2004). Firstly, in terms of objectives, in which Islamic cooperative is driven by profit and social motives while conventional cooperative relies more on profit motive. Social motives of Islamic cooperatives can be reflected through payment of zakat and infak. Secondly, is in terms of operational principle. Operation of Islamic cooperative is based on shariah and legal rules prevailing in the country. On the other hand, conventional cooperative operates based on legal rules only. No shariah conjunction is considered as basis for operational guideline.

Thirdly, sources of profit are also different for Islamic cooperative and conventional cooperative. They may come from profit earned from various Islamic modes of financing for the former while the latter receive profit from interest levied as financial service in every transaction. These incomes will be distributed to the members of cooperative during annual general meeting.

Fourthly, from the perspective of financing or lending, types of services of the two cooperatives are not the same. In Islamic cooperatives, different modes of financing require different types of services. For instance, an officer of Islamic cooperative is required to check market price of certain item sold through murabahah financing. He may go directly to the market in order to obtain the information needed. If a customer needs some fund for school tuition fee and *kafalah bil ujah* contract is applied, an officer of Islamic cooperative must go to the school and make payment in order to receive *ujrah* or fees. Otherwise the *ujrah* received is void from shariah perspective. Based on these examples, it is clear to say that different types of contract require different treatment. The same case will not happen in the context of conventional cooperatives since they use interest-based loan. They just charge additional amount of money for every loan given to customers.

Fifthly, there is a difference in the types of saving product offered to customer. As for Islamic cooperatives, in addition to principle saving, obligatory saving and voluntary saving, there exists zakat pool of fund, which is not found in the conventional cooperatives.

In reality, a number of problems may arise when Islamic cooperative is established. Lack of managerial skills and qualified human resources have been identified to be the major challenges faced by Islamic cooperatives industry. Therefore, quality improvement of management and human resources should be conducted periodically through various training and exchange of experience with other institutions (Buchori, 2009).

In the case of Indonesia, some of Islamic cooperatives are in the form of BMT (*Baytul Mal wa al-Tamwil*). Furthermore, a number of researches have attempted to analyze the impact of financing given by Islamic cooperatives and BMT to micro and small scale entrepreneurs. Astuti (2007) for instance, has evaluated level of business income of the micro entrepreneurs before and after receiving financing from BMT Beringharjo Kauman, Yogyakarta. Astuti finds that the financing given has increased income of the micro entrepreneurs from Rp 190,600.00 to Rp 316,000.00.

Similarly, Hidayat (2004) finds that financing provided by an Islamic cooperative, namely BMT Koppontren Hubbul Wathon, West Java, has increased income level of micro entrepreneurs by 90 percent. There are only 6.67 percent claiming that there is no change in their post-financing income. The remaining 3.33 percent acknowledge that their income has decreased.

Sakai and Marijan (2008) recommends the BMT and Islamic cooperatives to focus only on financing which is less than Rp 50 million. In other words, these Islamic microfinancing institutions should only concentrate only on micro and small scale business. Financing exceeding Rp 50 million should be provided by Islamic bank including Islamic rural bank, and not Islamic cooperatives.

Realizing the importance of Islamic microfinance, Seibel (2008) has suggested two ways of promoting Islamic microfinance. Firstly, is assisting Islamic commercial banks to establish units with Islamic microfinance products. Secondly, reassessing in a participatory process the challenges and realistic opportunities of Islamic rural banks and cooperatives, with a focus on effective internal control, external supervision, and the establishment of associations with apex services to their member institutions.

### **III. RESEARCH METHODOLOGY**

This section elaborates methodology applied by this study.

#### **3.1. Place and Time of Research**

This research is conducted at Kospin Jasa Syariah Pekalongan. This cooperative is purposively selected since it is the biggest Islamic cooperative based on the assessment made by the Ministry of Cooperatives and Small and Medium Scale Enterprises of Indonesia. The survey was conducted on February 2011 in Pekalongan city.

#### **3.2. Types and Sources of Data**

Two types of data comprising primary and secondary data are utilized by this study. Primary data is obtained through survey and interview with selected respondents, while secondary data comes from various sources consisting of Kospin Jasa Syariah Pekalongan, Central Board of Statistic, and other relevant materials including journals and scientific articles.

#### **3.3. Sampling Procedure**

Population of the research is defined as total number of micro and small scale entrepreneurs (MSE) who received financing from Kospin Jasa Syariah Pekalongan for the last year (February 2010 – January 2011) and they live in Pekalongan city. The financing given was amounted from Rp 1.60 million until Rp 50 million (USD 186.05 – USD 5,813.95). Total population is 197 entrepreneurs. Out of this number, 100 samples were purposively selected. These samples were classified into two groups: services and non-services sector.

#### **3.4. Analytical Methods**

There are two types of analysis used in this study: qualitative analysis and quantitative analysis.

##### **3.4.1. Qualitative Analysis**

Qualitative analysis is conducted based on qualitative data, which is obtained from questionnaire. This questionnaire is measured by using Likert scale. It is used to find out whether or not financing given by Kospin Jasa Syariah Pekalongan is effective. It is also intended to measure the impact of these financings to the members of Kospin Jasa Syariah Pekalongan in terms of business improvement, income level, asset increase, business capital, welfare level and basic needs fulfillment.

Assessment of the respondents is classified into four categories comprising effective, sufficiently effective, less effective and not effective. This assessment is needed to observe whether or not application and procedure of financing are effective. Data scoring is determined by the following formula:

$$\text{Total Score} = \text{Number of Respondents} \times \text{Score Value of Each Category} \dots\dots(1)$$

Total score for each procedure is ranging between 400 – 1200. This score range is obtained by multiplying the lowest and the highest score with the number of questions in the questionnaire and the number of respondents.

Since there are four categories of assessment, an interval for each category of assessment is highly needed. This interval is calculated based on the following formula:

$$\text{Interval} = \frac{\text{Maximum value} - \text{minimum value}}{\text{Total Number of Categories}} - 1 \dots\dots\dots(2)$$

From this formula, it is found that the interval for each category of assessment is equal to 199. Hence, the score for each category will be: **not effective** (total score ranging from 400-599), **less effective** (total score ranging from 600-799), **sufficiently effective** (total score ranging from 800-999), and **effective** (total score ranging from 1000-1200).

### 3.4.2. Quantitative Analysis

This study employs path analysis as its quantitative analytical method. Path analysis is designed to analyze pattern of relationship between variables and to observe direct or indirect influence of exogenous variable towards endogenous variable.

Path analysis is also used to predict the value of endogenous variable based on which exogenous variable that significantly affects the endogenous variable. It can also be employed to examine certain models via trimming theory, either for reliability test to already developed model or new model.

There are two structural equation models for path diagram used in this research. The first one is related with factors affecting financing application of the members of Kospin Jasa Syariah Pekalongan while the second one deals with the financing impact towards income level of the cooperative's members.

$$\text{PM} = \rho_{y1} \text{BA} + \rho_{y2} \text{LN} + \rho_{y3} \text{JA} + \rho_{y4} \text{PS} + \rho_{y5} \text{TP} + \rho_{y6} \text{AP} + \rho_{y7} \text{JU} + \epsilon_1 \dots\dots\dots(3)$$

whereby:

- PM = the amount of proposed financing application (rupiah)
- BA = cost of financing of the members (rupiah)
- LN = time duration of being member (months)
- JA = time duration of installment (days)
- PS = income level prior to financing (rupiah)
- TP = *dummy* for education level of the members  
DPi equals 1 if member's education is in high level ( $\geq$  Senior High School) and equals 0 if education level is in low level ( $<$  Senior High School)
- AP = *dummy* for financing allocation of the member  
AP equals 1 if financing is given for working capital and 0 for investment
- JU = *dummy* for business type of the member  
JU equals 1 for non services and 0 for services
- $\rho_{ik}$  = *path coefficient* for each exogenous variable *k*
- $\epsilon_i$  = *ith error*

$$PP = \rho_{y1}PM + \rho_{y2} KU + \rho_{y3} JA + \rho_{y4} AP + \rho_{y5} JU + \rho_{y6} PB \dots\dots\dots(4)$$

whereby:

- PP = post-financing daily income level of the member (rupiah)
- PM = the amount of financing taken by the member (rupiah)
- KU = daily business profit of the member (rupiah)
- JA = time duration for installment (days)
- PB = monthly consumption of the member (rupiah)
- AP = *dummy* for financing allocation of the member's business  
AP equals 1 if it is allocated for working capital and 0 for investment
- JU = *dummy* for business type of the member (1 for non services and 0 for services)
- $\rho_{ik}$  = *path coefficient* for each exogenous variable, *k*
- $\epsilon_i$  = *ith error*

#### IV. FINDINGS AND ANALYSIS

##### 4.1. Demographic Analysis of the Respondents

Table 2 below portrays the demographic profile of the respondents.

Table 2. Demographic Profile of the Respondents

No	Indicator	Number of Respondents	Percentage
<b>1.</b>	<b>Age Group</b>		
	<30	7	7
	30-50	82	82
	>50	11	11
<b>2.</b>	<b>Education Level</b>		
	Elementary School	2	2
	Junior High School	22	22
	Senior High School	66	66
	Diploma/Bachelor Holders	10	10
<b>3.</b>	<b>Business Types</b>		
	Non-services sector	79	79
	Services sector	21	21

Source: Authors' Own

Based on the table above, it is known that most of the respondents are in productive age ranging from 30 to 50 years old (82 percent). This number is considerably above the other two groups. As for education background of the respondents, almost two third of them are graduated from senior high school. This percentage is bigger than those graduating from elementary school and junior high school.

As for the business type, almost four fifth of the respondents are running business classified in the non-services sector. There are only 21 percent of the respondents who manage business in the services sector. It indicates that most of Kospin Jasa Syariah's members are in this type of business.

#### 4.2. Analysis of Financing Effectiveness

Effectiveness of financing can be observed from financing procedure which comprises application stage, fund disbursement stage, repayment stage and the effect of financing given. Table 3 below summarizes effectiveness of all financing procedure stages.

Table 3: Respondents Response on Financing Effectiveness

No	Response of Kospin Member	Total Score
1	Financing Application Stage	1139
2	Fund Disbursement Stage	1075
3	Repayment Stage	947
4	Financing Impact towards Member	1083
Average Score		1061

Source: Authors' own

From the Table 3, it can be observed that financing application stage is considered effective by the respondents. It indicates that respondents can accept requirements for financing application and they consider that the application process is easy and understandable. Kospin's service is also acceptable to the respondents and this service has become a key factor attracting new members of this Islamic cooperative to apply for financing.

Similar result also takes place in the second stage, i.e. fund disbursement stage. After application is approved, the Kospin Jasa Syariah will disburse the fund to the customers. The respondents are of the view that realization of the fund after approval takes very short period of time. In average, they will receive the fund less than a week. Therefore, the respondents agree that fund disbursement stage of Kospin is effective. Administrative cost, which sometimes occurs in certain types of contracts, is considered quite cheap and rationale. Respondents have no problem with the amount charged to them.

As for repayment stage, some of the respondents feel that repayment period is too short, which is less than one and a half year<sup>5</sup>. They also criticize officers of Kospin Jasa Syariah who never visit regularly since installment payment is conducted on regular basis<sup>6</sup>. Technical and managerial assistance should also be improved. When it is crosschecked to the management of Kospin Jasa Syariah, they admit that the cooperative is lack of human resources and therefore, priority of the field visit is focused on non performing financing. However, the installment amount is not burdening the respondents. In general, the respondents are of the view that repayment process is sufficiently effective.

<sup>5</sup> Actually this period of repayment is depending upon the types of contract and the nature of financed business. Hence, it may vary from one customer to other customer.

<sup>6</sup> Repayment period depends on the agreed contract. It can be on daily, weekly or monthly basis. There are two types of installment applied by Kospin. Firstly, installment paid contains component of principal amount and margin/fee/profit sharing. Secondly, installment paid contains only margin/fee/profit sharing. The principal amount will be paid at maturity date.

Last, but not least, is the impact of financing given towards the members of Kospin Jasa Syariah Pekalongan. In general, the presence of this Islamic cooperative is very helpful since it provides alternative source of fund other than money shark or informal money lender. After receiving the fund, the respondents acknowledge that their business is in better condition. Most of the fund received is used for working capital. As the result, their income level increases. This higher income is then utilized for two things: firstly, it is used to fulfill basic needs and secondly, it is used to increase business capital. Hence, in general the respondents receive a lot of benefits from financing given and this impact is considered effective.

After combining all results and taking the average of total scores, it is concluded that all processes starting from application procedure until repayment of fund and financing impact are considered effective.

### 4.3. Analysis of the Factors Affecting Financing Demand

The path analysis utilizes primary data obtained from the respondents. After collecting data and based on the equation (3) and (4) (vide section three above), we can get correlation matrix among exogenous variables as follows.

	BA	LN	JA	TP	AP	JU
BA	1.00					
LN	0.15	1.00				
JA	0.25	0.03	1.00			
TP	0.07	0.22	-0.05	1.00		
AP	-0.13	-0.01	-0.38	0.02	1.00	
JU	-0.02	0.02	0.06	-0.22	-0.09	1.00
PS	-0.13	0.07	0.14	0.05	-0.41	0.17
KU	-0.10	0.08	0.05	0.14	-0.10	0.09
PB	0.41	0.20	0.18	-0.05	-0.29	0.17

Figure 1: Correlation Matrix among Exogenous Variables

Based on the data depicted in the Figure 1, it is found that determinant coefficient (0.642250543) is greater than zero. It means that multicollinearity problem is not found and hence, this correlation matrix can be used for the next analysis. To examine the two equations (vide equation 3 and 4) we conduct deterministic coefficient test.

After estimated, the values of  $R^2$  for PM (the amount of proposed financing) and PP (post-financing daily income of the Kospin's member) are equal to 0.76 and 0.81, respectively. The values of path coefficients for PM ( $\rho e_1$ ) and PP ( $\rho e_2$ ) are 0.48 and 0.43, respectively. F statistic for PM model, which equals 41.62, exceeds the value of F-table. It can be concluded, hence, that all exogenous variables in the equation (3) affect the amount of financing. Similarly, F statistic for PP model, which equals 66.25, is greater than the value of F-table. It also indicates that all exogenous variables in the equation (4) affect post-financing daily income level of the member of Kospin Jasa Syariah. Furthermore, we conduct t-test for individual model. The results are as depicted in the Figure 2 below.

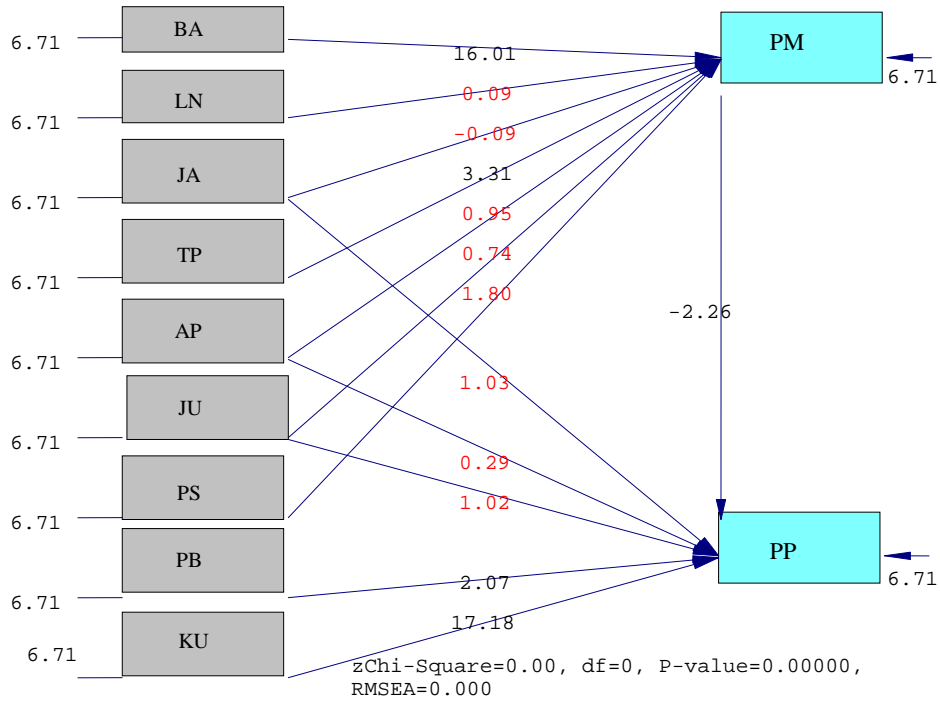

Figure 2: Complete Path Diagram

It is found that based on the test there exist path coefficients which are not significant (vide the red numbers in the Figure 2). Hence, models should be repaired by conducting *trimming model*. It means that we re-estimate the parameters or coefficients. The results are as portrayed in the following Table 4.

Table 4: Model Criteria of Path Analysis

Goodness-of-Fit	Cut-off-Value	Results	Notes
Chi-square ( $\chi^2$ )/df	$\leq 3$	0,00	<b>CLOSE FIT</b>
Significant Probability (P-Value)	$\geq 0,05$	0,00	<b>MARGINAL FIT</b>
RMR (Root Mean Square Residual)	$\leq 0,05$ or $\leq 0,1$	0,025	<b>CLOSE FIT</b>
RMSEA (Root Mean Square Error of Approximation)	$\leq 0,08$	0,39	<b>MARGINAL FIT</b>
GFI (Goodness of Fit Index)	$\geq 0,90$	0,86	<b>MARGINAL FIT</b>
AGFI ( Adjusted Goodness of Fit Index )	$\geq 0,90$	0,54	<b>MARGINAL FIT</b>
CFI (Comparative Fit Model)	$\geq 0,95$	0,73	<b>MARGINAL FIT</b>

Source: Authors' Own

Given the results, variables which are still *marginal fit* must be excluded from the structural equations. New equations must be re-constructed, which are as below.

$$PM = \rho_1 BA + \rho_2 TP + e_1 \dots\dots\dots(5)$$

$$PP = \rho_3 PM + \rho_4 KU + \rho_5 PB + e_2 \dots\dots\dots(6)$$

Whereby:

- PM = the amount of proposed financing application (rupiah)
- BA = cost of financing of the members (rupiah)
- TP = *dummy* for education level of the members  
 DPi equals 1 if member's education is in high level ( $\geq$  Senior High School) and equals 0 if education level is in low level ( $<$  Senior High School)
- PP = post-financing daily income level of the member (rupiah)
- KU = daily business profit of the member (rupiah)
- PB = monthly consumption of the member (rupiah)

We get new correlation matrix among exogenous variables as below.

	BA	TP	KU	PB
BA	1.00			
TP	0.07	1.00		
KU	-0.10	0.14	1.00	
PB	0.41	-0.05	0.33	1.00

Figure 3: Correlation Matrix among Exogenous Variables

Since determinant coefficient (0.01097181) is greater than zero, there is no multicollinearity problem among exogenous variables. After re-estimated, the value of  $R^2$  for PM model and  $\rho_{e1}$  are equal 0.78 and 0.48, respectively. Similarly, the value of  $R^2$  for PP model and  $\rho_{e2}$  are equal to 0.81 and 0.43, respectively.

Furthermore, t-statistic for path coefficients of  $\rho_{BA}$ ,  $\rho_{TP}$ ,  $\rho_{PM}$ ,  $\rho_{KU}$  and  $\rho_{PB}$  are explained in the following Figure 4.

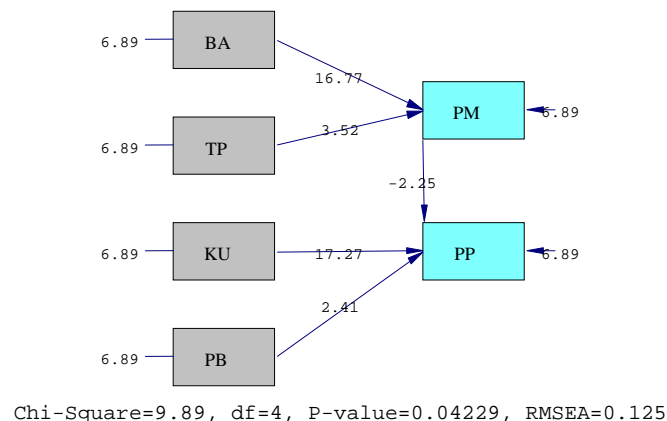

Figure 4: t-Test Path Diagram after Trimming

Based on the diagram above, it is known that since p-value is less than 0.05 the amount of proposed financing application (PM) individually is affected by cost of financing of the members (BA) and dummy for education (TP). As for post-financing daily income level of

the member (PP), it is influenced by the amount of proposed financing (PM), daily business profit of the member (KU), and monthly consumption of the member (PB).

The results lead to new estimated structural equations as below.

1. PM Model =  $0.84*BA + 0.28*TP$ , Errorvar.= 0.24 ,  $R^2 = 0.76$
2. PP Model =  $-0.11*PM + 0.85*KU + 0.3*PB$ , Errorvar.= 0.20 ,  $R^2 = 0.81$

Based on the two equations above, it is found that the models can estimate covariance matrix or population correlation matrix which is not different from sample correlation matrix. In other words, analysis on the samples can be generalized for the entire population of Kospin Jasa Syariah's members. Overall models have fulfilled *goodness of fit* assumptions.

Considering the results, it can be interpreted that the amount of proposed financing application (PM) is affected positively by cost of financing of the members (BA) and education level of the members (TP). BA affects PM by the value of  $(0.84)^2$  or 70.56 percent. As for TP, it affects PM by the value of  $(0.28)^2$  or 7.84 percent. Jointly, the two variables (BA and TP) affect PM by 0.76 or 76 percent (vide  $R^2$  value). It means that 76 percent of the amount of proposed financing application can be explained by cost of financing and education level. The former (BA) is found to have stronger effect compared to the latter (TP). The remaining 24 percent is explained by variables other than BA and TP.

The Kospin Jasa Syariah will allocate higher financing for the members by charging higher administrative cost and by looking at education level of the members. The higher education level of the members, the bigger is the amount of financing given. Kospin Jasa Syariah considers that educated members holding at least senior high school certificate, have better capability to manage their business as compared to those who are less educated.

As for the second equation, it is found that the post-financing daily income level of the member (PP) is positively affected by daily business profit of the member (KU) and monthly consumption of the member (PB) with the values of  $(0.85)^2$  or 72.25 percent, and  $(0.3)^2$  or 9 percent, respectively. However, PP is negatively affected by the amount of proposed financing application (PM) with the value of  $(-0.11)^2$  or 1.21 percent. When these variables are compared, KU is found to have the strongest effect on PP compared to the other two variables.

Jointly the three variables affect PP by the value of 0.81 or 81 percent. It means that 81 percent of the post-financing daily income level of the member can be explained by daily business profit of the member, monthly consumption of the member, and the amount of proposed financing application. The remaining 19 percent is explained by variables other than KU, PB and PM.

It can also be interpreted that higher post-financing daily income will enlarge daily business profit of the Kospin's members as well as their monthly consumption. When their income increases, there is a tendency for the members to reduce the amount of proposed financing in the subsequent application. As the implication, financing demand may fall. However, impact of this condition is very small as compared to the other two variables, i.e. business profit which has the strongest effect and monthly consumption expenditure.

## V. CONCLUSION

The presence of Islamic cooperatives has widened the opportunity for micro and small scale entrepreneurs (MSE) in accessing financial resources. Therefore, they must be given bigger room to play more roles in stimulating the growth of MSE as key player in the economy. Performance of several Islamic cooperatives indicates that this kind of institution has actually good prospect in the economic development scenario, although they are still lack of human resources.

After observing the performance of Kospin Jasa Syariah Pekalongan in providing financing for those whom are not fulfilling bankability requirements and interviewing 100 members of this cooperative, some conclusions can be drawn. Firstly, it is found that financing given by Kospin Jasa Syariah Pekalongan to its members in general is considered effective. This condition should be maintained and enhanced in the future.

Secondly, administrative cost and education level are found to be the factors affecting the amount of proposed financing application. It is very important for the Kospin Jasa Syariah to charge moderate administrative cost, which may reduce repayment burden of the members. As for education, the Kospin should improve technical and managerial assistance to its members in order to increase their business capacity. Regular visit should be conducted.

Last, but not least, post-financing daily income level of the member is affected by economic factors comprising business profit, monthly consumption expenditure and the amount of proposed financing application.

## REFERENCES

- Ahmed, H. 2004. *Role of Zakat and Awqaf in Poverty Alleviation*. Jeddah: IRTI-IDB.
- Anshori, A.G. 2006. *Gadai Syariah Di Indonesia*. Yogyakarta: Gadjah Mada University Press.
- Akbar, R.A. 2010. *Analisis Efisiensi Baitul Mal Wa Tamwil dengan menggunakan Metode Data Envelopment Analysis (DEA) (Studi pada BMT Bina Ummat Sejahtera di Jawa Tengah)* [Script]. Semarang: Diponegoro University.
- Aryati. 2006. *Analisis Permintaan dan Efektivitas Pembiayaan Usaha Kecil pada Lembaga Keuangan Mikro Syariah (Studi Kasus: KBMT Khidmatul Ummah, Bogor)* [Script]. Bogor : Bogor Agricultural University.
- Astuti, E. M. B. 2007. *Evaluasi Tingkat Pendapatan Usaha Kecil Sebelum dan Sesudah Memperoleh Pembiayaan dari BMT Beringharjo, Kauman, Yogyakarta* [Script]. Yogyakarta: Universitas Islam Indonesia.
- Baga, L.M. 2009. *Koperasi dan Kelembagaan Agribisnis*. Bogor: Department of Agribusiness of Bogor Agricultural University.
- Buchori, N.S. 2009. *Koperasi Syariah*. Mashun: East Java.

- Haron, S. dan Wan Azmi, W. N. 2005. *Measuring depositors' Behavior of Malaysian Islamic Banking System : A Co-Integration Approach. Proceeding of the 6<sup>th</sup> International Conference on Islamic Economics and Finance*, 21-24 November pp. 19-40.
- Hidayat, Y. 2004. *Efektivitas Pembiayaan Pola Bagi Hasil Pada Batul Maal wat Tamwil (BMT) Hubbul Wathon, Kecamatan Cilamaya, Kabupaten Karawang, Jawa Barat* [Script]. Bogor: Bogor Agricultural University.
- Kospin Jasa Syariah. 2009. *Laporan Pengurus dan Pengawas Tahun Buku 2009* [Annual Report]. Pekalongan.
- Sakai, M., and Marijan, K. 2008. *Policy Brief: Mendayagunakan Pembiayaan Mikro Islami*. Australia: Australia Indonesia Governance Research Partnership.
- Seibel, H. D. 2008. *Islamic Microfinance in Indonesia: The Challenge of Institutional Diversity, Regulation, and Supervision*. *Soujorn*, Vol. 23, No. 1, April 2008, pp. 86-103.